

## Art.: 3029

### Válvula de esfera accionamiento palanca / Ball valve lever handle

Características	Features
1. Válvula esfera con paso total.	1. Ball valve with full bore.
2. Construcción en latón s/ UNE-EN 12165 cromado.	2. Brass construction acc./ UNE-EN12165 chrome plated.
3. Extremos rosca gas (BSP) hembra según ISO 228/1.	3. Gas (BSP) threaded female ends according ISO 228/1.
4. Accionamiento mediante palanca de acero.	4. Working by means of steel lever handle.
5. Temperatura de trabajo desde -20°C a 110°C.	5. Working temperature from -20°C to 110°C.
6. Presión máxima de trabajo 25 bar (PN 25).	6. Maximum working pressure 25 bar (PN 25).
7. Asientos PTFE.	7. PTFE Seats.

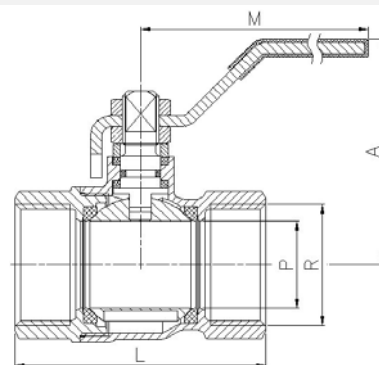
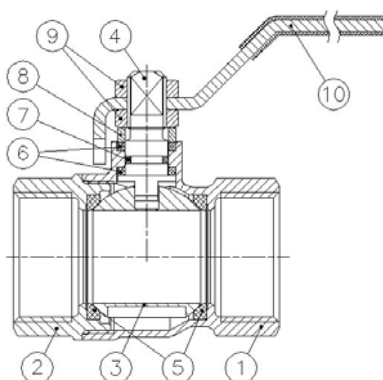

Nº	Denominación / Name	Material	Acabado Superficial / Surface Treatment
1	Cuerpo / Body	Latón / Brass (CW617N)	Granallado + Cromado / Peened + Chromed
2	Tapa / Cap	Latón / Brass (CW617N)	Granallado + Cromado / Peened + Chromed
3	Esfera / Ball	Latón / Brass (CW617N)	Cromado / Chrome plated
4	Eje / Stem	Latón / Brass (CW617N)	Cromado / Chrome plated
5	Asientos / Ball seats	PTFE	-
6	Anillo prensa / Stem packing	PTFE	-
7	Tórica / O-Ring	NBR	-
8	Anillo prensa / Stem ring	Latón / Brass	Cromado / Chrome plated
9	Tuerca / Nut	Latón / Brass	Cromado / Chrome plated
10	Maneta / Handle	Acero / Steel	Dacromet

Ref.	Medida / Size		Dimensiones / Dimensions (mm)					Peso / Weight (Kg)
	R	DN	P	A	L	M		
3029 02	1/4"	10	10	46	40	84	0,105	
3029 03	3/8"	10	10	46	43	84	0,110	
3029 04	1/2"	15	14	47	49	84	0,150	
3029 05	3/4"	20	19	58	56	98	0,250	
3029 06	1"	25	24	61	68	98	0,380	
3029 07	1 1/4"	32	30	74	80	126	0,595	
3029 08	1 1/2"	40	37	80	89	126	0,830	
3029 09	2"	50	46,5	91	104	158	1,330	
3029 10	2 1/2"	65	58,5	101	137	158	2,475	
3029 11	3"	80	72	131	158	196	3,925	
3029 12	4"	100	90	145	183	265	6,005	

## DIAGRAMA PÉRDIDA DE CARGA / HEAD LOSS CHART

(Válvulas paso total roscadas / Threaded ends full bore ball valves)

Valores de Kv / Kv Values:

**Kv** = Es la cantidad de metros cúbicos por hora que pasará a través de la válvula generando una pérdida de carga de 1 bar.

**Kv** = The flow rate of water in cubic meters per hour that will generate a pressure drop of 1 bar across the valve.

Medida / Size	1/4"	3/8"	1/2"	3/4"	1"	1 1/4"	1 1/2"	2"	2 1/2"	3"	4"
Kv	3.5	5.5	16	30	45	70	115	210	335	405	800

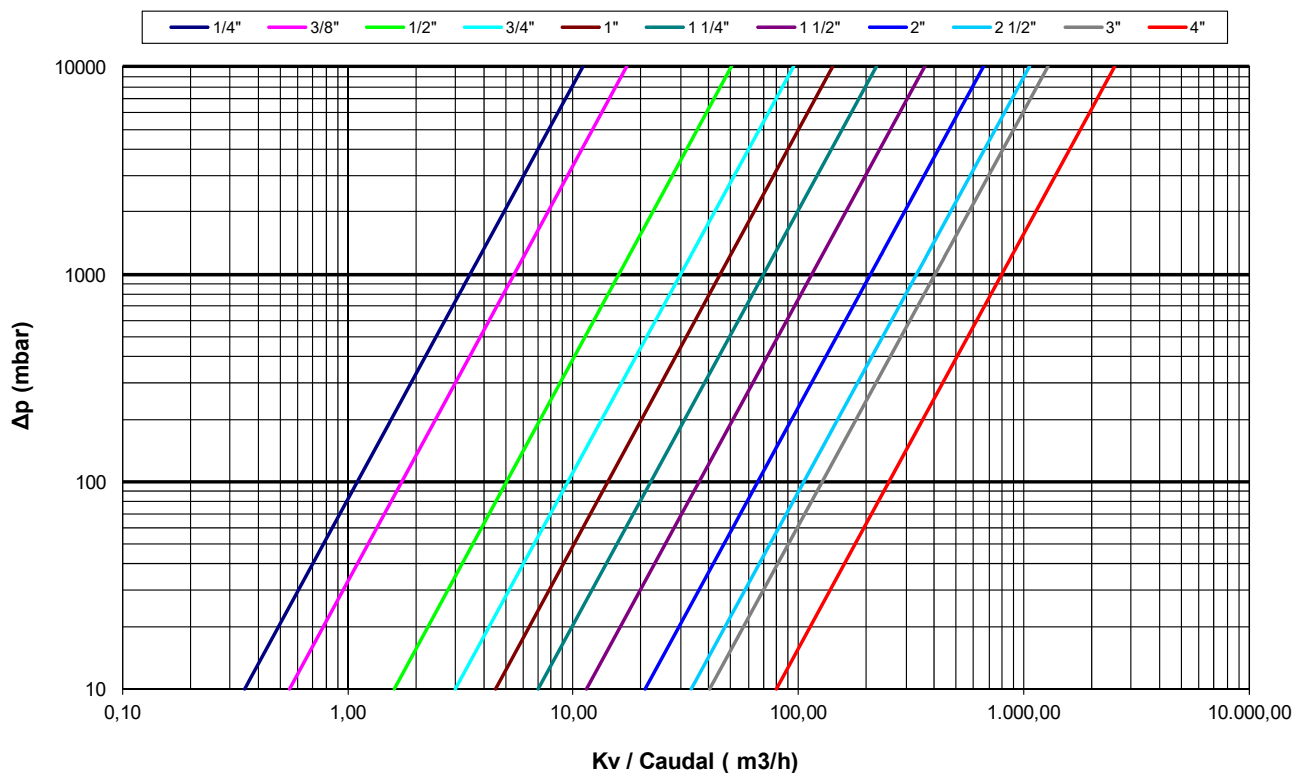

## CURVA PRESIÓN - TEMPERATURA / PRESSURE - TEMPERATURE RATING

